

NIXON & VANDERHYE
 APPLICATION OF: HARRISON et al.
 Serial No. Unknown, Atty Dkt. No.: 922-141
 "INTERFACE SYSTEM FOR WIRELESS NODE
 AND NETWORK NODE"
 Phone: 703-816-4002
 Atty: Larry S. Nixon

RS
 #
 2
 9-21-01

INVESTOR IN PEOPLE

The Patent Office
 Concept House
 Cardiff Road
 Newport
 South Wales
 NP10 8QQ



The undersigned, being an officer duly authorised in accordance with Section 74(1) and (4) of the Deregulation and Contracting Out Act 1994, to sign and issue certificates on behalf of the Comptroller-General, hereby certify that annexed hereto is a true copy of the documents originally filed in connection with the patent application identified therein together with the Statement of inventorship and of right to grant of a Patent (Form 7/77), which was subsequently filed.

In accordance with the Patents (Companies Re-registration) Rules 1982, if a company named in this certificate and any accompanying documents has re-registered under the Companies Act 1980 under the same name as that with which it was registered immediately before re-registration save for the substitution as, or inclusion as, the last part of the name of the words "public limited company" or their equivalents in Welsh, references to the name of the company in this certificate and any accompanying documents shall be treated as references to the name with which it is so re-registered.

In accordance with the rules, the words "public limited company" may be replaced by p.l.c., plc, P.L.C. or PLC.

Re-registration under the Companies Act does not constitute a new legal entity but merely subjects the company to certain additional company law rules.

Signed *W. Evans*

Dated 22 March 2001

**CERTIFIED COPY OF
 PRIORITY DOCUMENT**

THIS PAGE BLANK (USPTO)

1 FEB 2001

31 January 2001
Page 1

01FEB01 E602457-1 D02536
P01/7700 0.00-0102508.9

Patents Form No. 1/77

The Comptroller
The Patent Office
Cardiff Road
Newport
Gwent NP10 8QQ

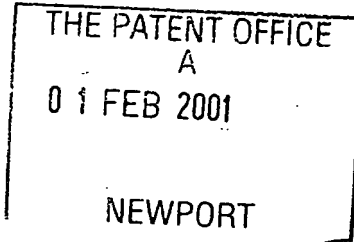

REQUEST FOR THE GRANT OF A PATENT

The grant of a patent is requested by the undersigned on the basis of the present application:

1. Title of the invention: INTERFACE SYSTEM FOR WIRELESS NODE AND NETWORK NODE

2. Applicants details: **0102508.9**

First or only applicant: 3Com Corporation

Country: US State: Delawaare

Address: 5400 Bayfront Plaza
Santa Clara
California 95052-8145
United States of America

~~7691009001~~
745 7546286001

3. Name of agent: BOWLES HORTON ADP Code: 8805003

Agent's address: Felden House, Dower Mews
High Street, Berkhamsted
Hertfordshire HP4 2BL

4. Agent's reference: 105331

5. The application claims an earlier date under any of Sections 8(3), 12(6), 15(4) or 37(4): NO

6. Declaration of Priority (if any)

Country	Application Number	Priority date
NONE		

Patents Form 1/77 (continued)

7. Inventorship

The applicant(s) is/are the sole inventor or joint inventors: NO

8. Check List of Documents:

A. The application is accompanied by the following number of sheets:

Request:	1
Description:	10
Claims:	1
Abstract:	1
Drawings:	6 (x2)

B. The application as filed is accompanied by the following:

Patents Form 7/77:	NO
Patents Form 9/77:	YES
Patents Form 10/77:	YES
Priority Document:	NO
Translation of priority document:	NO

9 Signature

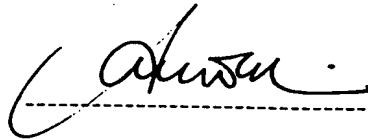

----- for BOWLES HORTON

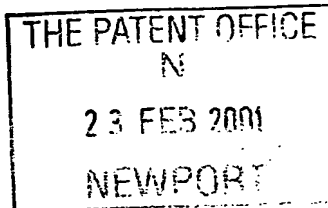

Patents Form No. 7/77

The Comptroller
The Patent Office
Cardiff Road
Newport
Gwent NO10 8QQ

STATEMENT OF INVENTORSHIP AND OF RIGHT TO THE GRANT OF A PATENT

Patent application No.0102508.9,

Title: INTERFACE SYSTEM FOR WIRELESS NODE AND NETWORK NODE

I/We: 3Com Corporation

the applicants in respect of the above-mentioned application for a patent declare as follows:

(i) I/We believe that the person(s) whose name(s) and address(es) are stated on the reverse side of this form is/are the inventor(s) of the invention in respect of which the patent application is made;

(ii) the derivation of my/our right to be granted a patent upon the said application is as follows:

by virtue of the employment of the inventors

(iii) I/We consent to the publication of the details contained herein to each of the inventors named on the reverse side of this form

Signature:  22 February 2001
for BOWLES HORTON (Authorised Agents)

Telephone: 01442 875961

Our reference: 105331

HARRISON, Lee Christian
4 Bankside Close
South Woodham Ferrers
Chelmsford
Essex CM3 5TT/GB 07793565001

TURNER, Edward
Yew Lodge, Holyport Road
Maidenhead
Berkshire
SL6 2EY/GB 08092702001

DONOGHUE, Bryan James
32 Ashtree Court
Granville Road
St Albans
Hertfordshire
AL1 5VE/GB 07869852001

LAM, Tin
15 Brookfield Avenue
LONDON
NW7 2DB/GB 08092710001

KERR, Benjamin James Ogden
33 Nettle Gap Close
Wootton Fields
NORTHAMPTON
NN6 6AH/GB 08092777001

INTERFACE SYSTEM FOR WIRELESS NODE AND NETWORK NODE

Field of the Invention

5 This invention relates to packet-based communication networks and particularly those which include a packet processing unit and wireless receivers or transceivers by which radio communication with a communication network is achieved. The present invention particularly relates to an interface link which facilitates separation of the wireless receiving and/or transmitting part of a network node and the high level packet processing functions or
 10 'protocol stack'.

Background to the Invention

15 In recent years much attention has been given to the extension of wireless links to local area networks or other packet-based communication networks which normally consist of various forms of packet generating receiving and processing units linked by physical links constituted by, for example, twisted pair lines, coaxial cable or optical fibres. Various standards are being developed for the wireless communication of data to and from nodes which form part of a packet-based communication network. One such standard is known as
 20 'Bluetooth'. The present invention in a preferred form is intended to be compatible with a Bluetooth standard but the subject matter of the invention is applicable to other systems.

25 It is known, from the systems operating in accordance with the Bluetooth standard, to provide a 'node' which is capable of receiving and/or transmitting a radio frequency signal, preferably in the form of a spread spectrum signal with 'frequency-hopped' coding. Such a node includes high level packet processing functions so that the node is immediately compatible, for example, with an Ethernet network. In such a node, the signals recovered from the baseband processing in the radio receiver are conventionally in a high speed serial data format. The transport layer for this high speed serial data is specified in the Bluetooth

specification as using either USB, RS232 or UART. For a variety of reasons it is not feasible to include substantial error detecting or correcting facilities in such a format and accordingly it is not desirable to have any substantial physical separation between the radio section of the node and the high level packet processing section.

5

Summary of the Invention

10

15

The main object of the present invention is to improve the interface between the radio receiving and/or transmitting section of a wireless node and the packet processing section and more particularly to enable a separation of the a wireless node into a 'dumb' node, which performs a conversion from the radio frequency signals to a signal format that is robust and can be used to convey data over substantial distances, and an 'intelligent' node, which is compatible with the aforementioned signal format and performs the packet processing or switch functions necessary for connection of data packets to a local area network or other network in which the node is connected. There is the further possibility that a multiplicity of 'dumb' nodes may share a single 'intelligent' node.

20

The present invention is based on a temporary conversion of passing between the radio receiver and/or transmitter and the intelligent node to an Ethernet format for the purpose of conveyance over a link between a dumb node and an intelligent node.

Further features of the invention will become apparent from the following description with reference to the accompanying drawings.

25

Brief Description of the Drawings

Figure 1 is a schematic illustration of a known form of wireless node for use according to the 'Bluetooth' network standard.

Figure 2 is a schematic diagram of a system comprising a 'dumb' and a 'intelligent' node according to the invention.

Figure 3 illustrates an encapsulation unit intended for use in the system of Figure 2.

5

Figure 4 illustrates an encapsulation unit intended for use in the system shown in Figure 2.

Figure 5 schematically illustrates various forms of frame that occur in the system of Figure 2.

10

Figure 6 illustrates a radio receiver which would normally form part of a system including the system of Figure 2.

Detailed Description of Exemplary Embodiment

15

Figure 1 of the drawings illustrates a known form of wireless node conforming to the 'Bluetooth' transmission protocol. It comprises a node 10 which has a RF section 1, a baseband section 2, a link management section, LMP(Link Management Protocol) 3, a serial link 4, an L2CAP decoder section 5, a point-to-point encapsulation section 6, denoted RFCOMM, a protocol stack 7, an Ethernet bridge 8 and a section 9 which attaches the bridge to a LAN or other network. The word 'section' is interchangeable with 'layer'.

20

The RF section 1 of the known node is commonly a spread spectrum receiver and transmitter which, as far the receiver is concerned, accepts a spread spectrum signal having a bandwidth of the order of 80 MHz (in the range 2400 MHz to 2480 MHz), converts the radio frequency signal to an intermediate frequency and after appropriate filtration and amplification converts the intermediate frequency signal to an appropriate lower frequency where the signal is split into I and Q components, preferably converted into digital form and subject to correlation employing a direct sequence code generator employing the same

25

code as was used to spread the spectrum of the original signal. The system will include appropriate synchronisers and baseband processing which provides serial data signals generally in a form of a preamble, an access code section and a payload (i.e. the message data). These packets will normally take the form of a 3 part packet with a 72 bit access code, a 54 bit header followed by a payload of between 0 and 2745 bits. The access code is used for synchronisation, DC offset compensation and identification, and has the format of a 4-bit preamble, an 64-bit sync word and a 4-bit trailer if a header follows. Section B of the Bluetooth specification V1.1 gives a complete list of access code formats and packet header types.

L2CAP is a protocol which is employed in the baseband for the purposes of protocol multiplexing, segmentation and reassembly. The various packet codes conforming to the protocol are embedded within the packet payload.

The link management section 3 of the known receiver is arranged to control the LMP Link Manager Protocol. This is used for link setup security and control. LMP messages have priority over the L2CAP data and are filtered out at the receiving side and are not propagated to the higher levels. Serial data is passed over the interface (known as the HCI or host controller interface). The section 5 decodes the L2CAP data and encapsulates it as packets conforming to a point-to-point protocol. These packets are conveyed to section 6. The RFCOMM protocol provides emulation of serial ports over the L2CAP protocol. This is based on ETSI standard TS 07.10. The purpose of RFCOMM is to provide a complete communications path between applications. RFCOMM is intended to cover applications that make use of the serial ports of the devices in which they reside. In a simple configuration the communication segment is a Bluetooth link from one device to another (direct connect). Where the communications segment is another network RFCOMM connects using a null modem type connection. In section 7 each of the RFCOMM stacks is terminated. An application running on top of this stack converts the PPP type data into valid

Ethernet packets with correct source and destination addresses, so that they can be processed by the Ethernet bridge which is illustrated with transmit and receive links 9.

5 The known system and other systems rely on a high speed serial link This is specified in the Bluetooth specification as either USB, RS232 or UART between a radio receiver and a packet processor.

10 The existence of this serial link is a physical constraint on the separation of the dumb or transducing part of the node and the 'intelligent' or packet processing part of the node. It is the object of the present invention to increase this physical separation by means of converting the serial data to Ethernet packets and reconvert them at the end of the link between the dumb and intelligent nodes.

15 The link setup for a voice in a Bluetooth system is done via TCS Binary (Telephony Control Protocol Specification). These signals appear as normal Bluetooth data and are sent through the Bluetooth stack as normal L2CAP data. This TCS Binary link is used to establish a separate PCM connection to the Bluetooth baseband section.

20 For the purpose of the Ethernet encapsulation, these PCM signals need to be tagged and multiplexed along with the HCI signals into Ethernet packets. The multiplexing can be carried out using a simple time division scheme. However to maintain a suitable quality of service for the voice connection, it is preferable that the voice data be given priority. At the receiving end the de-encapsulation logic needs to be able to recognise the tagged PCM data and be able to separate it from the other Bluetooth traffic and send it to either a handset at
25 one end or some type of digital exchange at the other. At either end of the link there will normally be some form of echo cancellation carried out using a simple digital signal processor.

Figure 2 illustrates schematically the main features of a system according to the invention. Figure 2 includes a baseband processor of the kind shown in Figure 1. The baseband processor and a link manager are connected to an Ethernet encapsulator/de-encapsulator 22 by means of lines 21 which convey HCI signals and PCM voice signals between the processor and encapsulator/de-encapsulator and also include a further line which will become apparent later. The encapsulator/de-encapsulator includes an encapsulator as shown in Figure 3 and a de-encapsulator shown in Figure 4 connected at one side to the baseband processor and at the other side to a suitable physical link 23 (shown as a length of coaxial cable) for the conveyance of Ethernet signals to an Ethernet encapsulator/de-encapsulator 24. This is similar to the encapsulator/de-encapsulator 22. It includes an encapsulator of the kind shown in Figure 3 for converting signals to Ethernet form over the link 23 to the de-encapsulator in section 22 and a de-encapsulator of the kind shown in Figure 4 for de-encapsulating Ethernet packets received over the link 23. The encapsulator/de-encapsulator 24 is connected by lines 25 to an intelligent node 26 which includes a high level protocol processor 6, corresponding to the stack 6 in Figure 1, a PCM voice decoder 27 and a node management section 28. Ethernet packets which are developed by the high level protocol processor are coupled out on a physical link 29, again shown as a length of coaxial cable.

In this particular system, there is provision not only for the conveyance of HCI data in high speed serial form and its encapsulation as Ethernet packets for the physical link between the dumb node and the intelligent node but also provision for sending PCM voice data.

Figure 3 illustrates an encapsulation unit of which one each would be provided in each of the encapsulator/de-encapsulators 22 and 24. The encapsulator shown in Figure 3 is annotated on the assumption that it is part of the encapsulator/de-encapsulator 22; the encapsulator in block 24 is similar but reversely oriented.

The encapsulator shown in Figure 3 receives on line 21-1 a high-speed serial data signal of the general kind shown at 50 in Figure 6 to be described. It also receives on line 21-2 pulse

code modulated voice data. These lines 21-1 and 21-2 are connected to a buffer module 32. Within the buffer modules 32 is a dual FIFO, one for the Bluetooth (HCI) data and one for the voice (PCM) data. The module 32 interleaves data from the FIFO's before outputting a single data stream to the multiplexer 33. Preferably the buffer module 32 tags each of the HCI or PCM packets with a configurable byte (or longer tag if desired) added to the front of the packet. The tag identifies the packet type (HCI or PCM) and the packet size. The tag is used by the de-encapsulator (Figure 4) to split up the Ethernet packet employed to convey the HCI and PCM packets over the link 23. The start and end blocks of the HCI data are detected in a detector 34. When the start of an HCI block is detected, a bit counter 35 commences running, sensing the bits on the line 21-1. The counter is stopped when the end block of the HCI data is detected. The counter data is compared with preset 'watermarks' (i.e. threshold values) for each of the FIFOs in buffer module 32. PCM data is sensed by detector 36 which is coupled to the counter 35. The counter data is also used when the FIFOs within the buffer module 32 do not contain enough data to form a whole Ethernet packet. If this is the case the counter will wait for a predetermined length of time, waiting for more HCI or PCM data, before triggering the packet padder which will provide padding data to supplement the existing HCI or PCM data to form at least a minimum length Ethernet packet.

This arrangement allows more than one HCI or PCM packet to be encapsulated in an Ethernet packet and ensures that the Ethernet packet is at least its prescribed minimum length.

When the counter signals the end of an HCI packet the packet buffer is signalled to provide an output to a demultiplexer 33

Multiplexer 33 also has an input of line 21-3 which is coupled to the manager. Also coupled to the multiplexer are Ethernet header registers 31.

When the system is switched on, a control signal on line 24 will initialise the header registers 31. The purpose of these is to supply headers for Ethernet packets made up of those headers and packet data taken from the buffer 32. Such Ethernet packets are passed through
5 a CRC generator 38 which computes the CRC code in ordinary manner and adds the CRC data at the end of the Ethernet packet in normal manner.

As a preliminary to the encapsulation of HCI data to Ethernet packets, the link manager on start up of the node will generate what are known as 'negotiation' packets which are
10 dedicated multicast packets that are coupled by way of the multiplexer 33 to the link 23. The purpose of these packets is to elicit a response which identifies the MAC address of the processor 26 so that the Ethernet packets may be properly headed with a MAC destination address.

Figure 4 shows the de-encapsulator. Ethernet packets on the line 23 are coupled through a
15 CRC checker 41. If the incoming packet is a negotiation packet it is detected by detector 42 which provides a control to a multiplexer 43 to drive the negotiation packet out on line 25-3. In Figure 4 these packets will go out on line 25-3 to the high level protocol processor. In the reverse direction, the negotiation packets will be directed to the link manager in order to
20 provide a MAC address for coupling to the Ethernet header registers 31.

If however the packets received over line 23 are not negotiation packets, the Ethernet header is detected by detector 45 in order to provide a control for the removal of the Ethernet header as the packets are read into buffer 44 splitting the Ethernet packet into an HCI packet
25 and/or pulse code modulation signals to be fed out on lines 25-1 and 25-2 respectively. Once the Ethernet header has been removed, the tags appended to the front of each of the HCI or PCM packets determine whether the packets are sent out on line 25-1 (for HCI packets) or 25-2 (for PCM packets).

Figure 5 illustrates the relationship between the HCI data frames and the Ethernet frames.

There are several different types of HCI packets, for example Command Packets, ACL data packets, SCO data packets and negotiation packets. These are all specified in detail in the Bluetooth specification. For the purpose of this invention the HCI packets are transmitted to the encapsulation logic in their RS232 transport format which consists of an 8 bit packet identifier, and 8 bit sequence and finally the packet payload, the length of which can be determined by the packet identifier. The Ethernet frame 51, shown in somewhat simplified form, consists of a start of frame delimiter (SFD) a destination address (typically a 48-bit MAC address), a source address (typically a 48-bit MAC address), the rest of the header, which is in a generally prescribed form not relevant to the present invention, the tag added by module 32, a section which corresponds to the HCI packet, denoted HCI # 1, padding, a CRC section and an end of frame section. The description of Figure 3 assumes that the HCI frames are shorter than the minimum length of an Ethernet frame and do not exceed the maximum length. It also assumes that a single HCI frame will be converted, with padding if necessary, to a frame conforming to the Ethernet protocol. However, as indicated in the foregoing a multiplicity of HCI frames could be included in a single Ethernet frame, as shown in frame 51. The padding may be meaningless data but could be in the format of an HCI packet which has the destination of a null stack and can therefore be discarded.

Figure 5 shows only HCI frames in the Ethernet frames but as indicated above PCM frames can be included in the Ethernet frames.

Figure 6 illustrates for completeness a spread spectrum transmitter and receiver of the kind intended for use in a Bluetooth node. This will only be described in formal terms, since the form of the receiver is prescribed according to the Standard.

The receiving part of the node comprises an antenna 60, a bandpass filter 61 (restricting the input signal to the range 2400 GHz to 2480 GHz), amplified by RF amplifier 62, again

bandpass filtered in filter 63 and coupled to a first mixer 64, which receives a signal from a frequency-hopping synthesizer 65 controlled by a frequency-hopping sequence generator 66. The output from the first mixer (either 110 MHz or a low-frequency intermediate frequency, such as 4 MHz) is bandpass filtered by a channel filter 67, amplified by intermediate frequency amplifiers 68 and 69 and demodulated in a demodulator 70, the baseband output being processed in baseband processor 20 (see Figure 1).

The transmitter section is in ordinary form and consists of a baseband processor 71, converting HCI data and PCM voice data to an appropriate modulated form, and a spread spectrum transmitter 72 coupled to an antenna 73. The spread spectrum transmitter will include a mixer receiving the baseband signal and the output of a sequence generator, and up converters for converting the spread spectrum signal to the appropriate radio frequency band.

Claims

1. A system for receiving data signals, comprising:

5 a radio receiver including a baseband processor for providing serial data signals composed of data frames each including a packet payload;

means for encapsulating said data frames within Ethernet packets;

10 a transmission link for conveying said Ethernet packets; and

means for receiving the Ethernet packets from said link and de-encapsulating said Ethernet packets to recover said data frames.

15 2. A system according to claim 1 and further comprising means, coupled to receive said data frames from said means for receiving, for converting said data frames into addressed Ethernet packets.

20 3. A system according to claim 1 and including means for tagging said data frames before they are encapsulated within Ethernet packets.

4. A system according to claim 1 wherein the means for encapsulating inserts at least one of said data frames followed by padding data into the message section of an Ethernet frame.

25 5. A system according to claim 1 wherein said radio receiver is a spread spectrum radio receiver.

Abstract

5

An interface between a wireless node and a network node includes an encapsulator for temporarily converting data frames into Ethernet frames for the link between the two nodes and de-encapsulating the Ethernet frames before the data is processed at the network node.

10

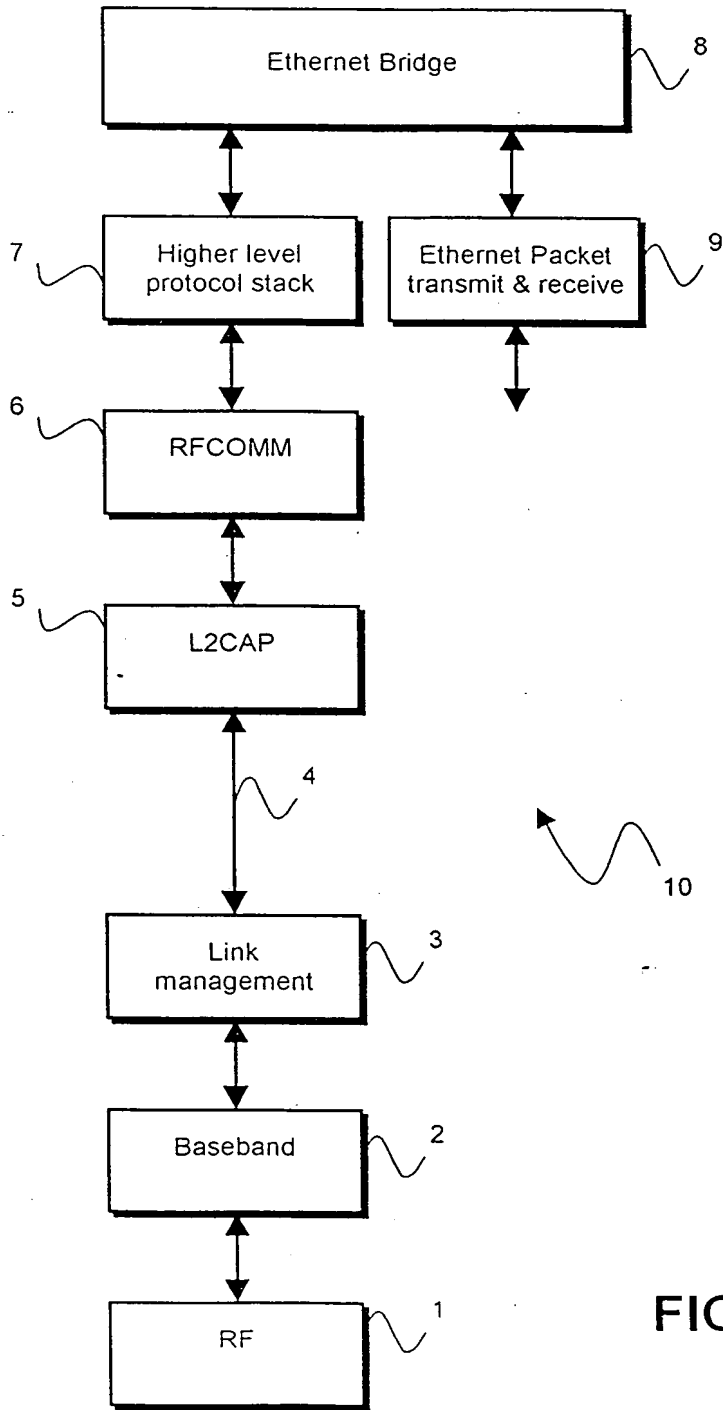

FIG.1

THIS PAGE BLANK (USPTO)

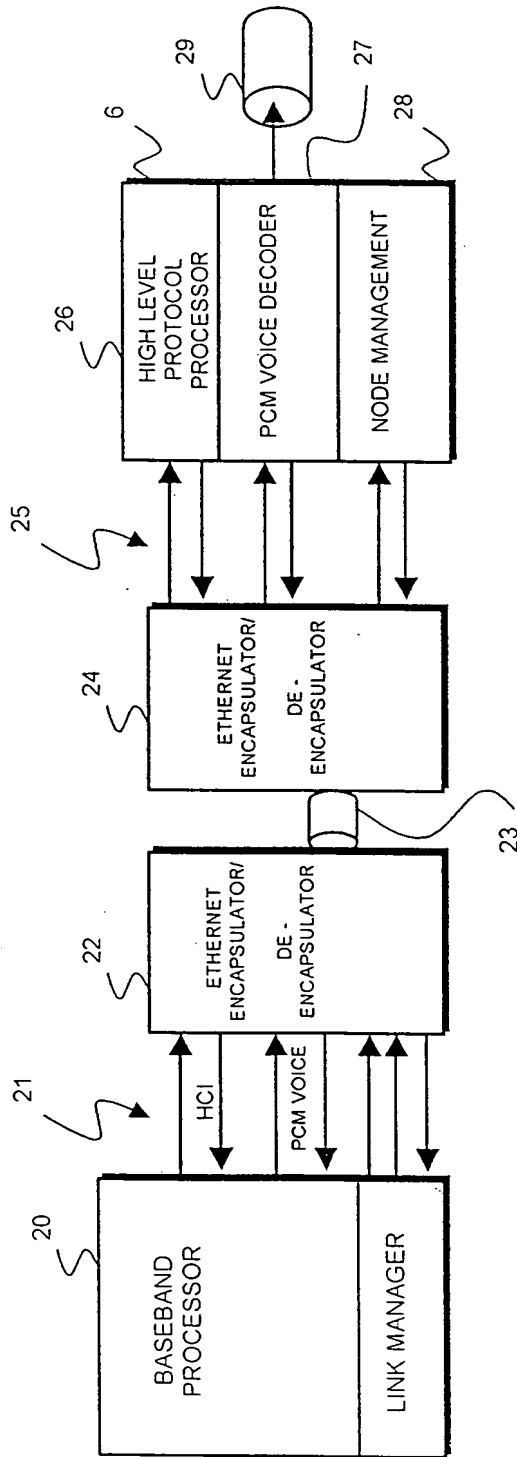

FIG.2

THIS PAGE BLANK (USPTO)

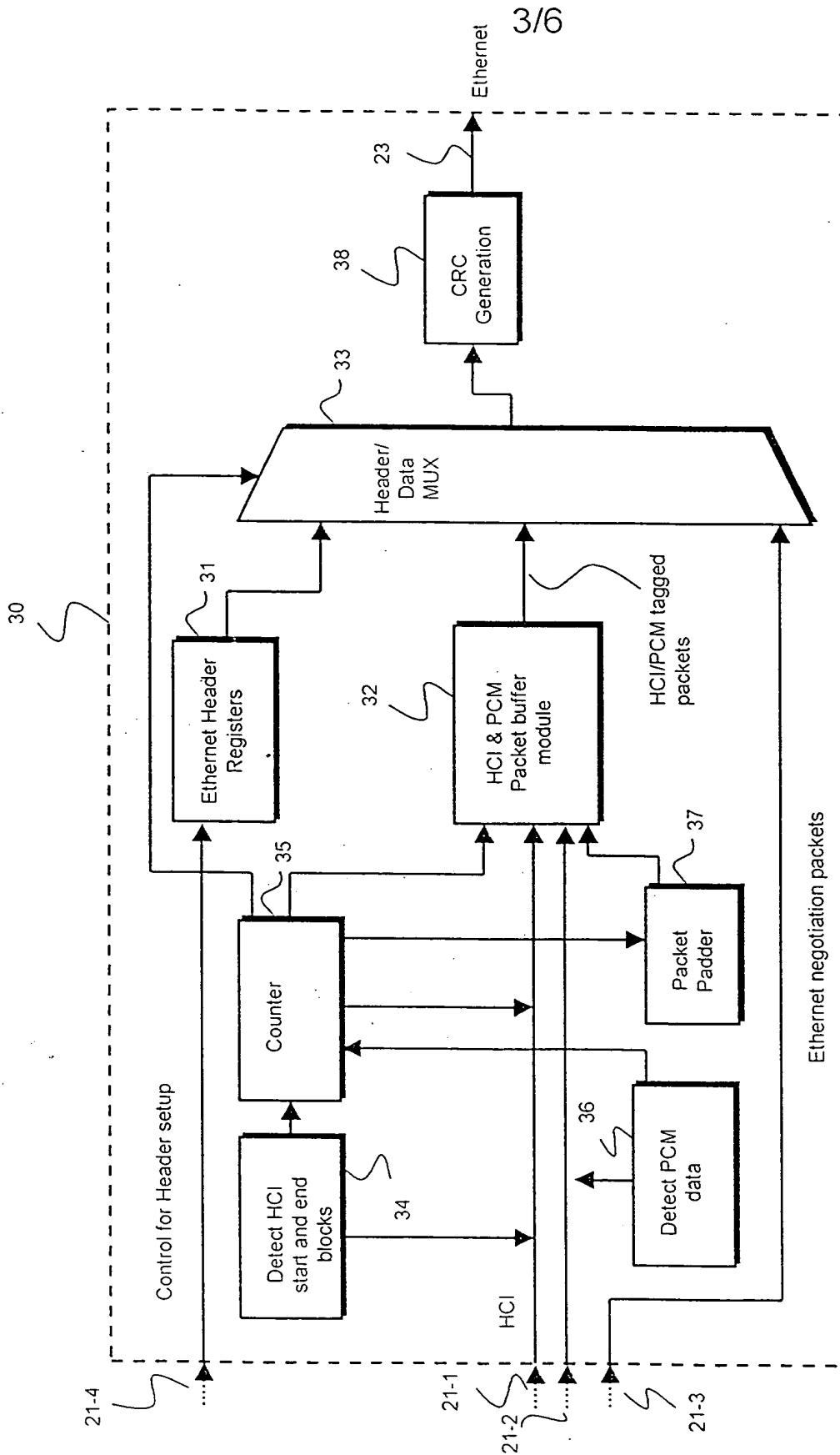

FIG.3

THIS PAGE BLANK (USPTO)

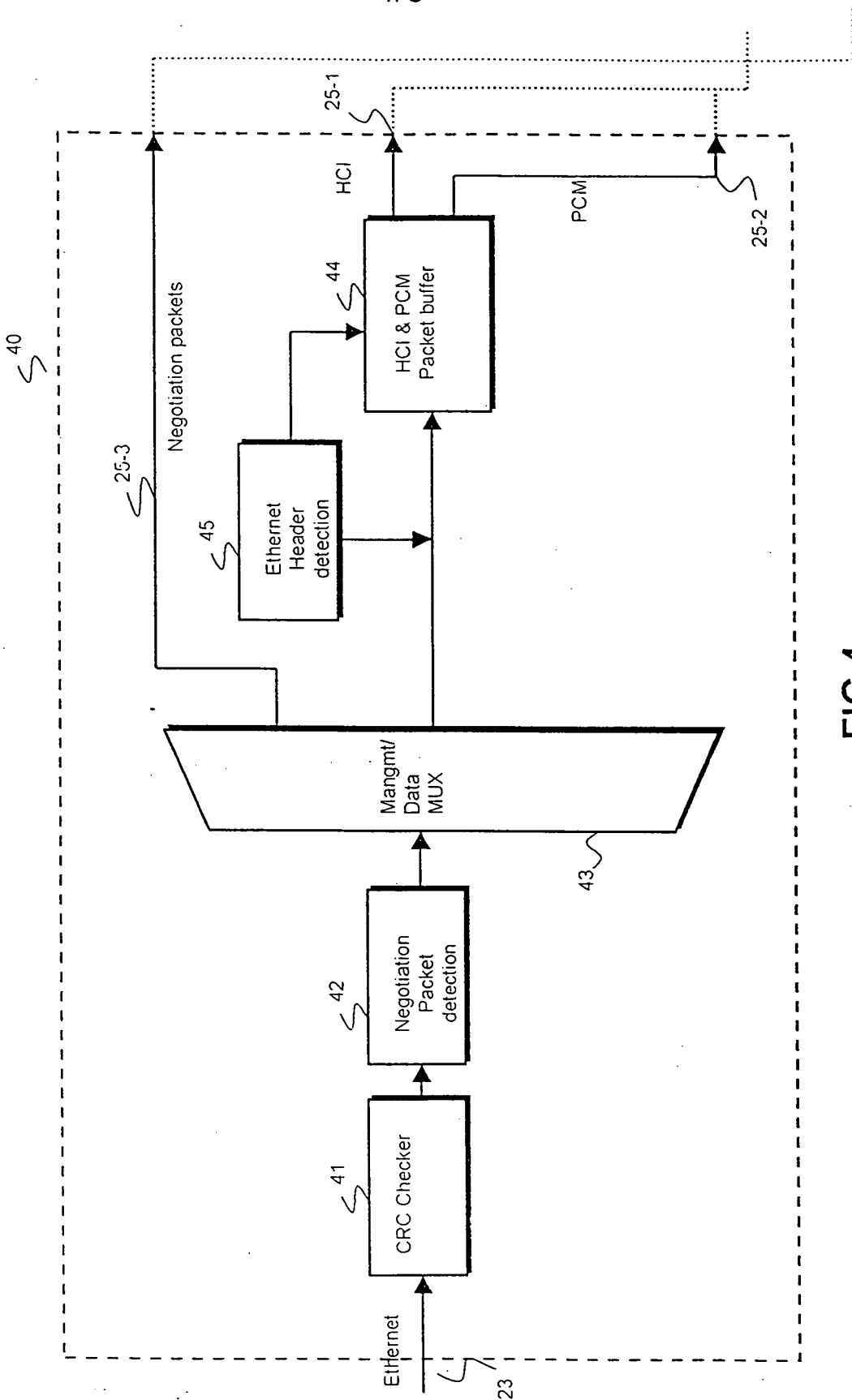

FIG.4

THIS PAGE BLANK (USPTO)

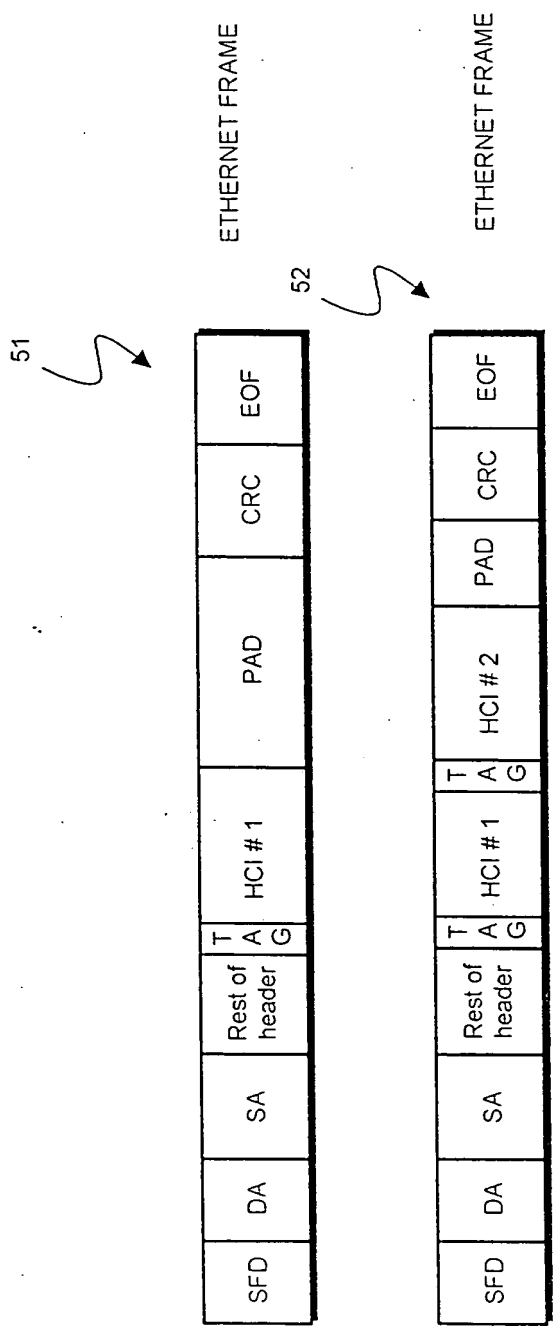

FIG.5

THIS PAGE BLANK (USPTO)

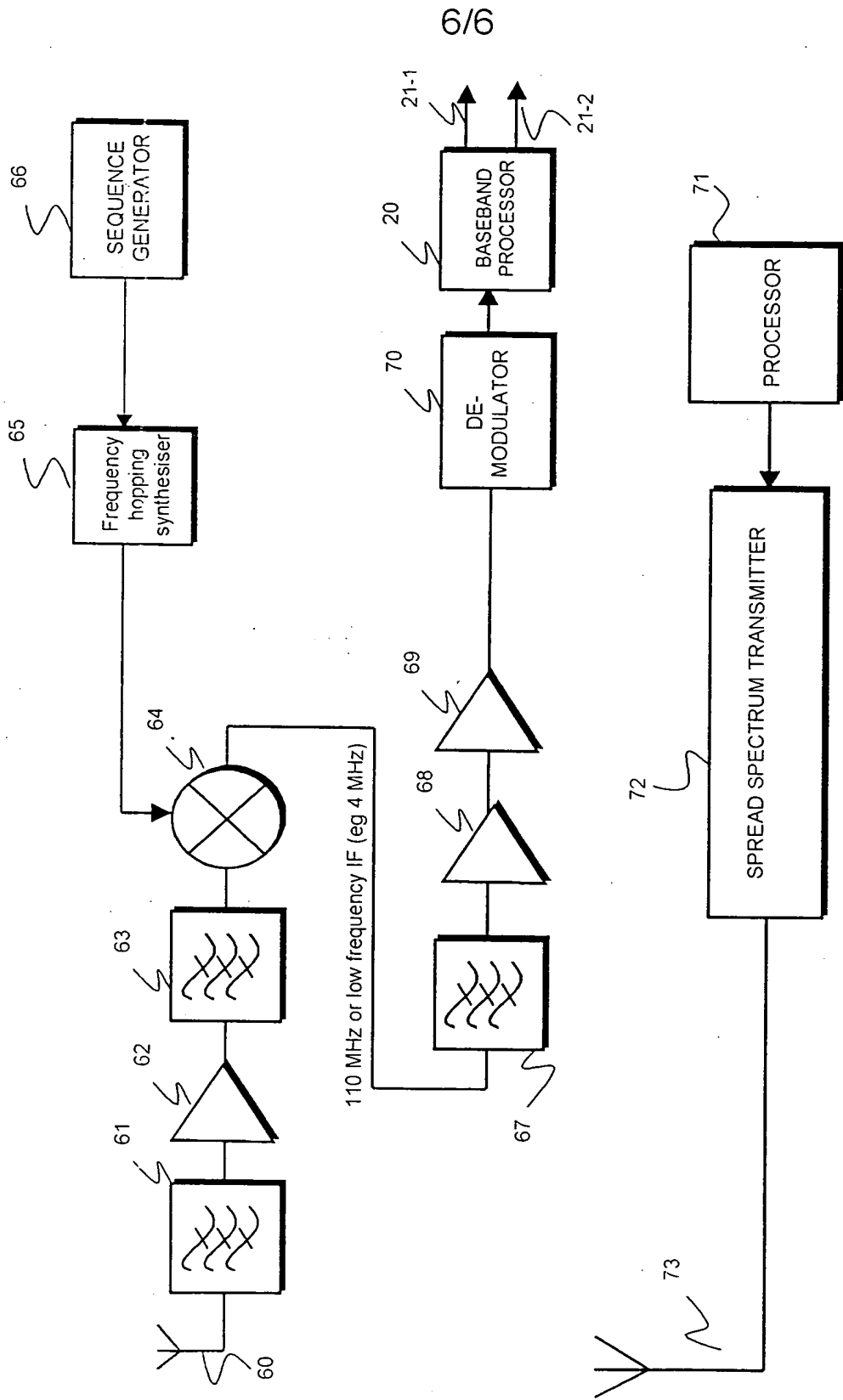

FIG.6

THIS PAGE BLANK (USPTO)